

ZIBELINE INTERNATIONAL
PUBLISHING

ISSN: 2710-6012 (Online)

CODEN: JWBAO

Journal of Wastes and Biomass Management (JWBM)

DOI: <http://doi.org/10.26480/jwbm.02.2020.49.52>

CrossMark

RESEARCH ARTICLE

EXTRACTION OF ESSENTIAL OILS FROM TAMARIND LEAVES AND SEED USING MICROWAVE EXTRACTION

Mohammad N. A. Abdullah Zawawi, Ahmed H. A. Dabwa*, Lili S. Hassan

Faculty of Chemical Engineering Technology, University College Tati, Jalan Panchor, Teluk Kalong, 24000 Kemaman, Terengganu, Malaysia.

*Corresponding Author Email: drahmedtati@gmail.com

This is an open access article distributed under the Creative Commons Attribution License, which permits unrestricted use, distribution, and reproduction in any medium, provided the original work is properly cited.

ARTICLE DETAILS

Article History:

Received 20 September 2020

Accepted 22 October 2020

Available online 04 November 2020

ABSTRACT

Tamarind (*Tamarindus indica*) belongs to the family Leguminosae. It is commonly growing in tropical and subtropical regions now and is one of the most important plant resources as cuisine materials. Antioxidative activity of tamarind seeds was investigated. An ethanol extract prepared from the seed coat contained antioxidative activity as measured by the thiocyanate and thiobarbituric acid (TBA) method. Essential oils are highly odorous droplets found in minimal quantities in the flowers, stems, leaves, roots and barks of aromatic plants. They are not recognized as true oils as the vegetable oils, but highly fluid and volatile. Experts recognize an essential oil by its aroma and test the oil characteristics such as vaporization and crystallization point using Differential Scanning Calorimetry (DSC). DSC has emerged as a powerful experimental technique for determining thermodynamic properties of biomacromolecules. Volatile components of tamarind leaves and seed locally grown will be isolated by Microwave Assisted Extraction (MAE). The presence of essential oil as the volatile components will be investigated to determine whether this method is effective or not to extract the oil from tamarind leaves and seed. The parameters that will be measured are the time for the oil droplets formation and the optimum temperature for the extraction of oil. At the end of the extraction, amber color oil was obtained. Results showed that the time for the oil droplets formation increasing with the increasing weight of sample for both tamarind leaves and seed samples. The optimum temperature for the extraction obtained was 125°C with the yield of 1.2 mL of seed oil. The vaporization and crystallization point of oil are presented in the DSC curve and the specific heat capacity of the oil are calculated.

KEYWORDS

Antioxidative, DSC, MAE, TBA, biomacromolecules.

1. INTRODUCTION

Essential oils are highly odorous droplets found in minimal quantities in the flowers, stems, leaves, roots and barks of aromatic plants (Spink, 2008; Bakkali and Idaomar, 2008). They are not recognized as true oils as the vegetable oils, but highly fluid and volatile. They are used in the medical field thanks to their biocidal activities (bactericidal, virucidal and fungicidal) and medicinal properties (El Asbahani, 2015). Tamarind (*Tamarindus indica*) belongs to the family Leguminosae (Vishwanath et al., 2006). It is commonly growing in tropical and subtropical regions now and is one of the most important plant resources as cuisine materials. The pulp is mostly being used in spices and seasoning as it contained sour taste, and it is accepted as herb medicine in parts of the world (Kumar and Bhattacharya, 2008). Tamarind fruit pulp is also used in curries, sauces, and juices (Kader et al., 2013). The flower and leaves are eaten as vegetables.

However, the seed coat of tamarind has been rarely used, making its potential underused and there has been no attention to the seeds from the viewpoint of antioxidative activity (Santos Sou et al., 2017). Antioxidative activity of tamarind seeds was investigated (Tril et al., 2014). An ethanol

extract prepared from the seed coat contained antioxidative activity as measured by the thiocyanate and thiobarbituric acid (TBA) method. Volatile components of tamarind leaves and seed locally grown will be isolated by Microwave Assisted Extraction (MAE). The presence of essential oil as the volatile components will be investigated to determine whether this method is effective or not to extract the oil from tamarind leaves and seed (Bustamante, 2016). The parameters that will be measured are the time for the oil droplets formation and the optimum temperature for the extraction of oil. The sample of essential oils from tamarind seed will also be tested using Differential Scanning Calorimetry (DSC) to determine the vaporization and crystallization point of oil (Guidelines et al., 2019).

Synthetic antioxidants such as butylated hydroxytoluene (BHT) and butylated hydroxyanisole (BHA) are the effective antioxidants. Their applications have helped a lot in the food industries. However, these synthetic antioxidants are suspected to be carcinogenic and thus very dangerous to be used continuously. Tocopherol is a natural antioxidant and it is less effective than synthetic ones. It is also not carcinogenic but the manufacturing cost is high. Because of the bad sides from the used of synthetic and natural antioxidants, the extraction of essential oils from

Quick Response Code



Access this article online

Website:
www.jwbm.com.myDOI:
10.26480/jwbm.02.2020.49.52

certain plants as the antioxidant agents was introduced (Selmi et al., 2017). The disadvantages of commonly used sample- preparation techniques such as hydro distillation (HD) and liquid solvent extraction are that they usually need a large amount of organic solvents and manpower; these methods is tended to be destructive in nature (Huie, 2002). The application of hydro distillation (HD) and liquid solvent extraction can cause losses of some volatile components, low extraction efficiency, degradation of unsaturated or ester compounds through thermal or hydrolytic effects (Conde-Hernandez et al., 2017). Toxic solvent residue in the extract may also be found. These deficiencies have led to the consideration of the use of new "green" technique in essential oil extraction, which typically use less solvent and energy, such as supercritical fluids, ultrasound and microwave (Lucchesi et al., 2004).

Hydro distillation (HD) required long extraction time, followed by evaporation of water and essential oil (Chen et al., 2016). A typical Supercritical Fluid Extraction (SFE) system built up of a high-pressure pump that transports the fluid and an extraction cell containing the sample. It is maintained at the fixed pressure and temperature. Due to the numerous parameters affecting the extraction efficiencies, SFE affords a high degree of selectivity. However, on the other hand, this makes the optimization quite exhausting and difficult in practice. The Microwave Assisted Extraction (MAE) method required heating for 30 min only of the plant sample and evaporation of the water and essential oil of the plant material (Chan et al., 2011). This technique with the reducing of cost for extraction is clearly will be the advantage for the proposed MAE method in terms of energy and time (Bagherian et al., 2011; Mandal et al., 2006).

2. MATERIAL AND METHODS

2.1 Sample preparation

Fresh plant material will be purchased from the market at Kemaman. The leaves of tamarind that already exist in small size make it easy for sampling. The seed need to be obtained by removing the pulp of tamarind. One tamarind fruit contained four seeds. Seed was obtained from tamarind fruit and dried under the sun for 3 days. After that, seed was crushed and grinded using grinder and then filtered to get the sample in powder form.

2.2 Extraction Method

Before beginning the process of extraction, tamarind seeds need to be dried to reduce the moisture content. The next steps of size reduction by crushing, grinding and filtering the seed to form powder which increases the surface area to facilitate easier extraction.

2.2.1 Leaf sample

Five grams of tamarind leaves will be weighed and put into a round bottomed flask. Without adding any solvent to the sample, put the flask into the microwave. The sample must be heated using a fixed power of 500 W and controlled temperature of 100 °C. The time taken for the formation of first essential oil droplet is recorded. The experiment then need to be repeated using different amount of 10g, 15g, 20g and 25g leaves sample.

2.2.2 Seed sample

Using Soxhlet extraction apparatus, 5g of tamarind seeds will be weighed and placed in a thimble-holder before placing it into the Soxhlet apparatus. Then 300ml of hexane will be placed into a round-bottomed flask as the solvent for extraction and the flask will be attached to the heating mantle. The temperature of heating mantle will be set to 100 °C. Open the water flow for the condenser and start the extraction process. During the operation, the sample will be gradually filled with condensed solvent from round- bottomed flask. When the liquid reaches an overflow level, a siphon aspirates the whole contents of the thimble-holder and unloads it back into the flask, carrying the extracted analytes in the bulk liquid. This operation is repeated until complete extraction is achieved. Figure 1 shows the Soxhlet extraction apparatus setup.

The extracted oil will be mixed together with the hexane solvent. A Rotavapour apparatus will be used to separate the oil from hexane. The

oil-hexane mixture will be attached to the bump trap on rotary evaporator and partially submerged into water bath. During the process, the mixture will be rotated and the solvent will be separated from the oil and condensed into a different flask. Figure 2 shows the Rotavapour apparatus. By using 10g of seeds sample, the sample will be heated using different temperature and the quantity of essential oil obtained will be measured. The differences in the quantity of essential oil obtained determine the optimum temperature of the heating mantle. The essential oil will be collected, dried under anhydrous sodium sulphate and stored at 0 °C until it is used for analyzing.

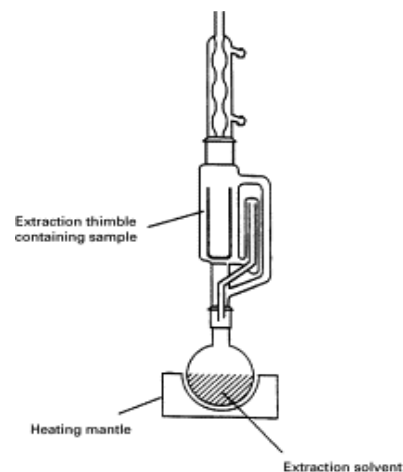

Figure 1: Soxhlet extraction apparatus

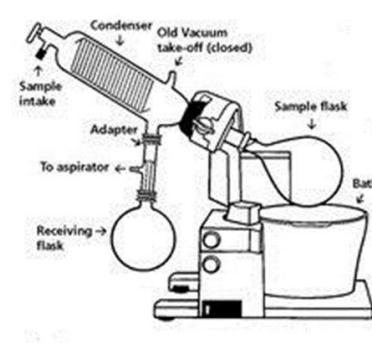

Figure 2: Rotavapour apparatus

2.3 Differential Scanning Calorimetry (DSC) Analysis

Differential Scanning Calorimetry (DSC) is a thermal analysis technique in which the heat flow into or out of a sample is measured as a function of temperature or time, while the sample is exposed to a controlled temperature program. A small amount of oil sample (1-15 mg) will be contained within a closed crucible and placed into a temperature-controlled DSC cell. Before placing into the cell, the sample will be weight. A second crucible without sample was used as a reference. Open the gas flow (nitrogen) and start the cooler. Start the DSC by setting the procedure through a PC. The data will be obtained in the form of curve and the data of vaporization/melting and crystallization point of tamarind seed oil will be collected and recorded. Figure 3 shows the DSC apparatus.

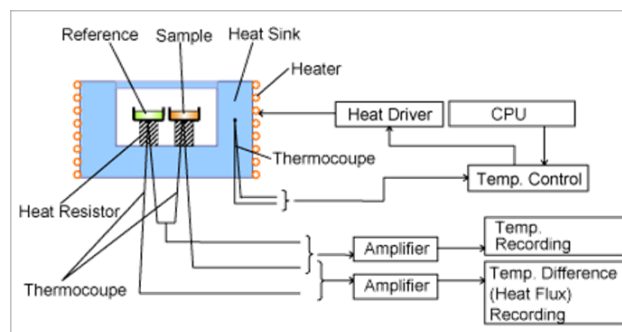

Figure 3: DSC apparatus

3. RESULTS AND DISCUSSION

3.1 Time Taken for the Essential Oil Droplet Formation

The time for the oil droplets formation increasing with the increasing weight of sample for both tamarind leaves and seed samples. Figure 4 shows 21 second time taken for the oil droplet formation of tamarind leaves sample with the highest weight of 25 grams. In the Figure 5, only 26 minutes time taken for the oil droplet formation of 25 grams tamarind seed sample. The volume of essential oil obtained also increase with the increasing weight of tamarind seed and leaves samples. From Figure 6, the highest yield of oil obtained was 1.2 mL with the weight of 25 g of tamarind seed sample. The time taken was only 26 minutes proving that this method of microwave assisted extraction (MAE) required shorter time of extraction compared to the hydro-distillation (HD).

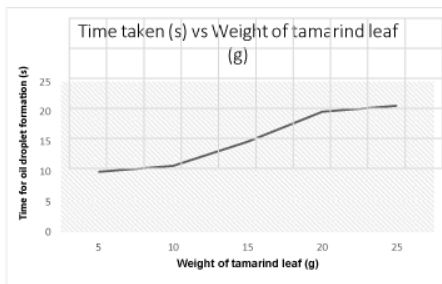

Figure 4: Leaves Sample

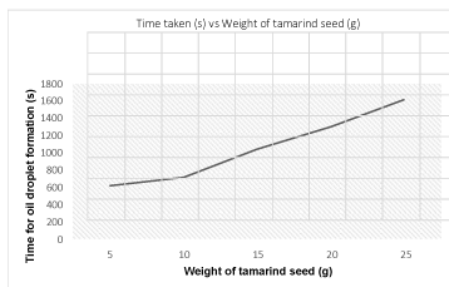

Figure 5: Seed Sample

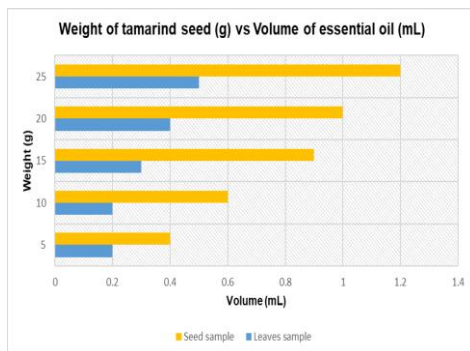

Figure 6: Volume of essential oil obtained

3.2 Optimum Temperature for Extraction

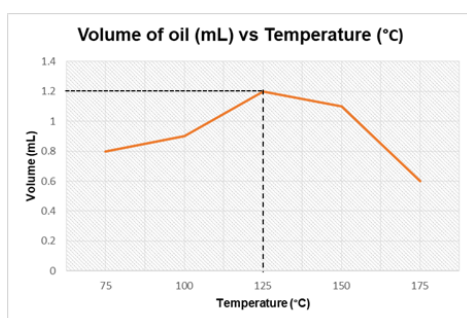

Figure 7: Optimum temperature for extraction

The optimum temperature for the extraction obtained was 125 °C with the yield of 1.2 mL of seed oil. The further increasing in temperature will not increase the yield of oil obtained as the extraction efficiency started to decrease. Figure 7 shows the yield start decreasing with further increase of temperature beyond the optimum temperature.

3.3 Vaporization and Crystallization Point of Tamarind Seed Oil

Table 1: DSC Analysis			
Differential Scanning Calorimetry (DSC) Analysis			
Tamarind Oil	Standard (°C)	Sample (°C)	Specific Heat Capacity (J/gK)
Vaporization Point	120 to 180	140	241.05
Crystallization Point	-5.9 to -0.43	-3.17	31.15

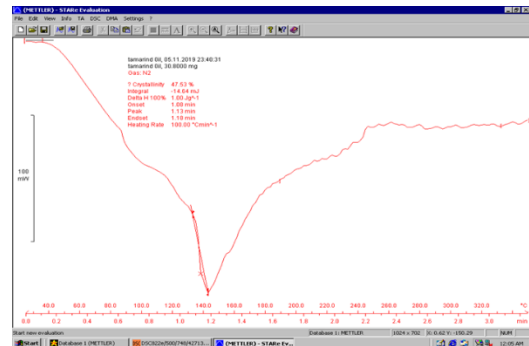

Figure 8: Vaporization point of oil

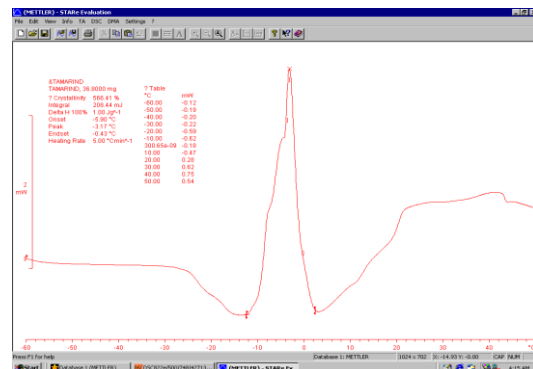

Figure 9: Crystallization point of oil

The vaporization / melting point of the oil sample obtained from Figure 8 was 140°C. The standard tamarind seed oil melting point was between 120°C to 180°C. the crystallization point of the oil sample obtained in Figure 9 with the reading of -3.17°C. The standard tamarind seed oil melting point was between -5.9°C to -0.43°C. Thus, the result showing that the melting and crystallization point of the oil sample were within the standard range. Table 1 shows the specific heat capacity for vaporization and crystallization of oil. The specific heat capacity of the tamarind seed oil was calculated using the formula:

$$s = q / (m \times \Delta T)$$

where,

s = specific heat capacity (J/gK) q = heat (J)

m = mass of sample (g)

ΔT = change in temperature (K)

4. CONCLUSION

The proposed method of Microwave Assisted Extraction (MAE) is an original combination of microwave heating and Soxhlet Apparatus. This method offers important advantages over traditional alternatives, namely: shorter extraction times (30 min for MAE method against 4.5 h for hydro-

distillation), substantial savings of energy, and a reduced environmental burden (less CO₂ rejected in the atmosphere). It is highly recommended for development of existing methods of separation such MAE and introduction of new techniques of high resolution and effectiveness.

ACKNOWLEDGEMENTS

University College Tati.

REFERENCES

- Bagherian, H., Ashtiani, F.Z., Fouladitajar, A., Mohtashamy, M., 2011. Comparisons between conventional, microwave- and ultrasound-assisted methods for extraction of pectin from grapefruit. *Chem. Eng. Process. Process Intensif.*, 50 (11-12), Pp. 1237-1243.
- Bakkali, F., Idaomar, M., 2008. Biological effects of essential oils – A review. *Food and Chemical Toxicology*, 46 (2), Pp. 446-475.
- Bustamante, J., 2016. Microwave assisted hydro-distillation of essential oils from wet citrus peel waste. *J. Clean. Prod.*, 137, Pp. 598-605.
- Chan, C.H., Yusoff, R., Ngoh, G.H., Kung, F.W.L., 2011. Microwave-assisted extractions of active ingredients from plants. *J. Chromatogr. A.*, 1218 (37), Pp. 6213-6225.
- Chen, F., Du, X., Zu, Y., Yang, L., Wang, F., 2016. Microwave-assisted method for distillation and dual extraction in obtaining essential oil, proanthocyanidins and polysaccharides by one-pot process from Cinnamomi Cortex. *Sep. Purif. Technol.*, 164, pp. 1-11, 2016.
- Conde-Hernández, L.A., Espinosa-Victoria, J.R., Trejo, A., Guerrero-Beltrán, J., 2017. CO₂-supercritical extraction, hydrodistillation and steam distillation of essential oil of rosemary (*Rosmarinus officinalis*). *J. Food Eng.*, 200, Pp. 81-86.
- El Asbahani, E., 2015. Essential oils: From extraction to encapsulation. *Int. J. Pharm.*, 483 (1- 2), Pp. 220-243.
- Guidelines, A., Code, A. Form, and C. Universitaria, 2019. Language Fatty Olive Oil Quality. Pp. 1-9.
- Huie, C.W., 2002. A review of modern sample-preparation techniques for the extraction and analysis of medicinal plants. *Anal Bioanal Chem.*, 373 (1-2), Pp. 23-30.
- Kader, M.A., Islam, M.R., Parveen, M., Haniu, H., Takai, K., 2013. Pyrolysis decomposition of tamarind seed for alternative fuel. *Bioresour. Technol.*, 149, Pp. 1-7.
- Kumar, C.S., Bhattacharya, S., 2008. Tamarind seed: Properties, processing and utilization. *Crit. Rev. Food Sci. Nutr.*, 48 (1), Pp. 1-20.
- Lucchesi, M.E., Chemat, F., Smadja, J., 2004. Solvent-free microwave extraction of essential oil from aromatic herbs: comparison with conventional hydro-distillation. *Journal of Chromatography A*, 1043 (2), Pp. 323-327.
- Mandal, V., Mohan, Y., Hemalatha, S., 2006. Microwave Assisted Extraction - An Innovative and Promising Extraction Tool for Medicinal Plant Research PHCOG REV: Review Article Microwave Assisted Extraction – An Innovative and Promising Extraction Tool for Medicinal Plant Research,".
- Selmi, S., Rtibi, K., Grami, D., Sebai, H., Marzouki, L., 2017. Rosemary (*Rosmarinus officinalis*) essential oil components exhibit anti-hyperglycemic, anti-hyperlipidemic and antioxidant effects in experimental diabetes. *Pathophysiology*, 24 (4), Pp. 297-303.
- Sou, D.S., Ba, C.A., da Silva, O.J.W., Teixeira, F., Teixeira, H.G., 2017. Quantitative Profile of Fatty Acids and Tocopherols in Tamarind Seeds (*Tamarindus indica* L.) From Different States of Brazil. *Res. J. Phytochem.*, 11 (3), Pp. 118-128.
- Spink, C.H., 2008. Differential Scanning Calorimetry. *Methods Cell Biol.*, 84 (7), Pp. 115-141.
- Tril, U., Fernández-López, J., Álvarez, J.Á.P., Viuda-Martos, M., 2014. Chemical, physicochemical, technological, antibacterial and antioxidant properties of rich-fibre powder extract obtained from tamarind (*Tamarindus indica* L.). *Ind. Crops Prod.*, 55, Pp. 155-162.
- Ushanandini, S., Nagaraju, S., Kumar, K.H., Vedavathi, M., Machiah, D.K., Kemparaju, K., Vishwanath, B.S., Gowda, T.V., Girish, K.S., 2006. The anti-snake venom properties of *Tamarindus indica* (leguminosae) seed extract. *Phytother Res.*, 20 (10), Pp. 851-858.

